



CRESCENT BUILDERS

www.builtbycrescent.com

THE SONOMA 3230 SQUARE FEET*



ELEVATION "A"

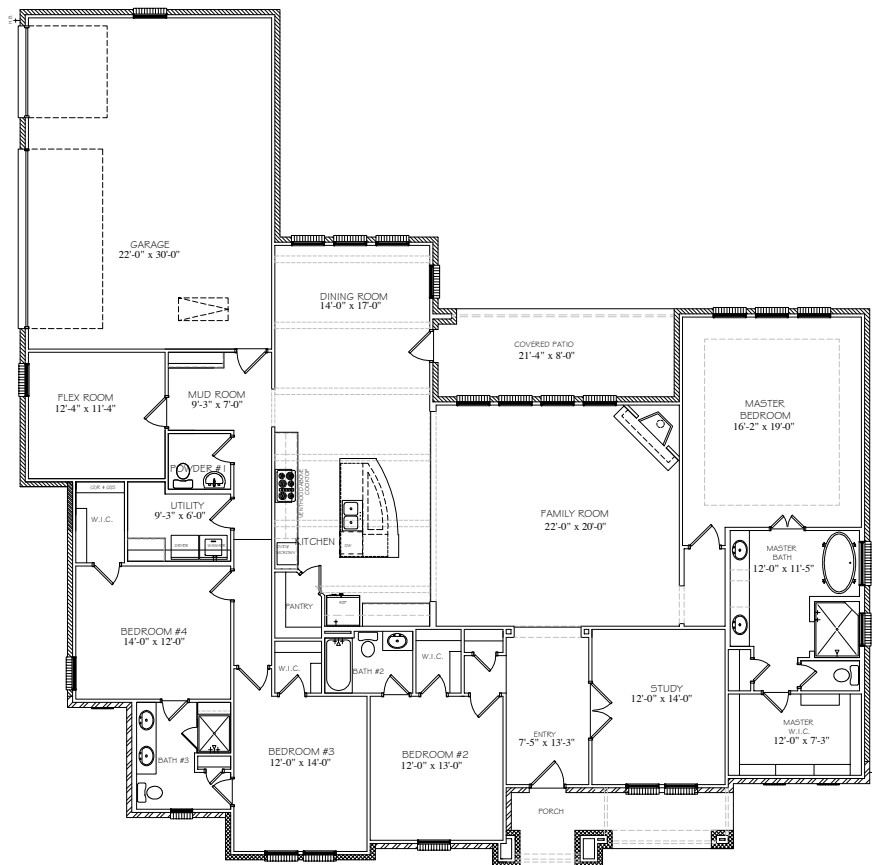

FIRST FLOOR PLAN

5-26-20



EQUAL HOUSING
OPPORTUNITY

2017 **CRESCENT BUILDERS** All Rights Reserved. No portion of this material may be reproduced in any form or by any means, including photocopying, without the express written permission of the **CRESCENT BUILDERS** Company. The **CRESCENT BUILDERS** Company will vigorously prosecute any unauthorized use of this material. **CRESCENT BUILDERS** reserves the right to alter square footage, room measurements or exterior elevations.

DOOR SCHEDULE		
SIZE	SIZE	QUANTITY
1668	INTERIOR	1
2068	INTERIOR	3
(2)1668	INTERIOR PAIR	1
2468	INTERIOR	9
(2)2668	INTERIOR PAIR	1
2868	INTERIOR	6
2868	SOLID CORE	1
2868	EXTERIOR FULL LITE	1
3080	EXTERIOR	1
16070	OVERHEAD	1
8070	OVERHEAD	1

WINDOW SCHEDULE	
SIZE	QUANTITY
30/70 SH HEB DL	2
30/60 SH DL	2
16/26 FG DL, OBSCURE	2
30/60 SH DL	1
20/40 FG DL	1
30/60 SH	13
30/50 SH	1
40/50 FG	1
30/20 FG	1

HATCH LEGEND	
	BRICK
	STONE
	STONE WAINSCOT

SQUARE FOOTAGE CALCULATIONS	
AREA	SQ. FT.
FIRST FLOOR	3230
PORCH	119
PATIO	172
GARAGE	721
TOTAL A.U.R.	4242
WIDTH	77' 2"
DEPTH	77' 11"

1ST FLOOR PLAN "A"

SCALE: 1/4" = 1'-0" (22"x34" SHEET)
1/8" = 1'-0" (11"x17" SHEET)

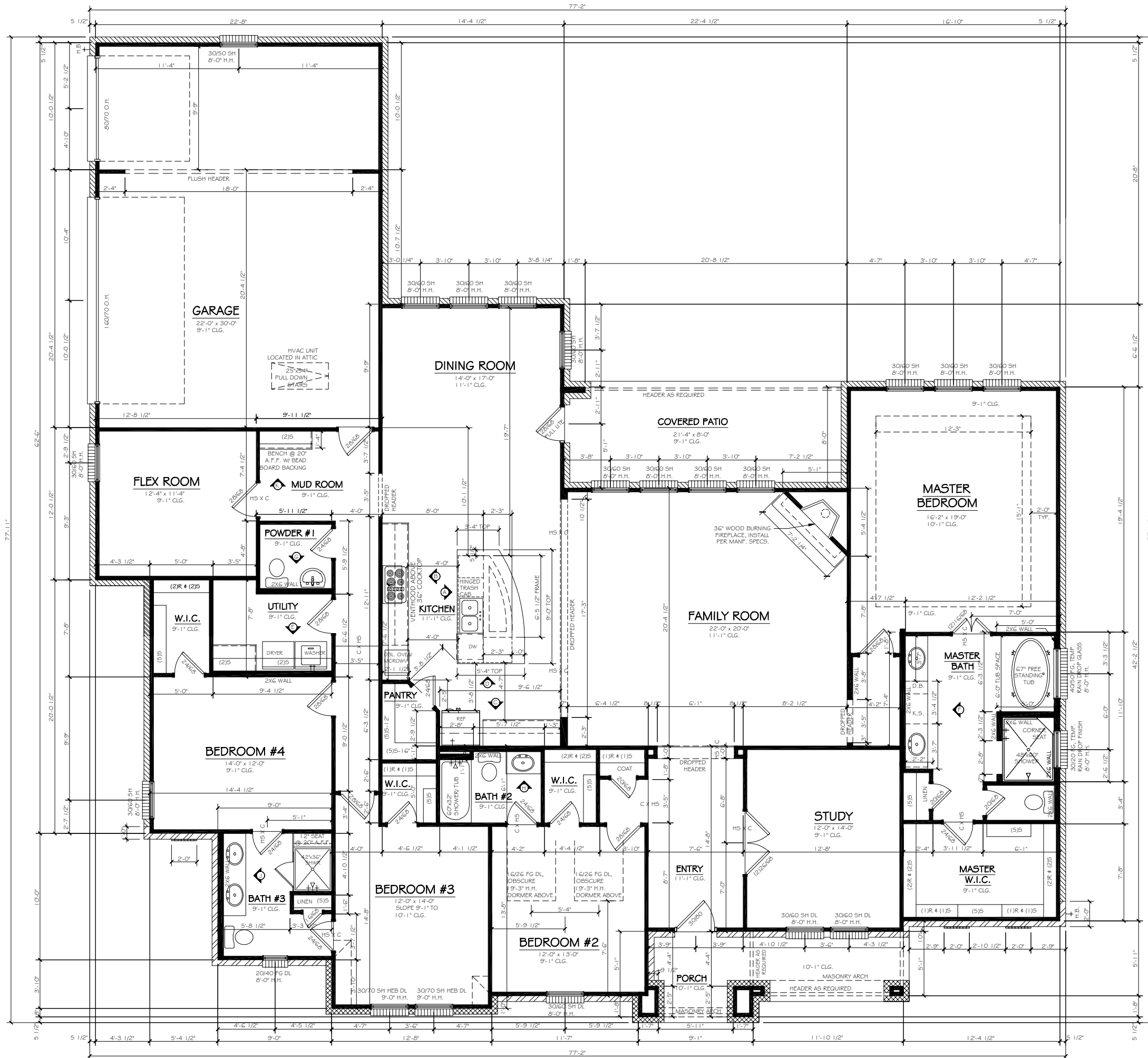

1501 LYNX LOOP, LOT 2 BLOCK E, LYNX HOLLOW, FORNEY TX

CONCEPT DATE:
12-6-16 NB
PRINTED DATE:
3-23-17 NB, 9-11-17 NB,
8-2-18 NB, 2-28-20 NB,
3-9-20 NB, 5-26-20 SM

CRESCENT BUILDERS
Phone: 972/999-4360
www.builtbycrescent.com



SCALE:
1/8" = 1'-0" (11x17) SHEET
1/4" = 1'-0" (22x34) SHEET

PLAN NUMBER
3072
FLOOR PLAN
"A"

PAGE 1 OF 7

ELECTRICAL LEGEND	
⊕	SWITCH
⊕ ₃	THREE-WAY SWITCH
⊕ ₄	FOUR-WAY SWITCH
⊕ _R	RHEOSTAT
⊕	DUPLEX
⊕ _{GFI}	GFCI DUPLEX
⊕ _{CT}	COUNTERTOP DUPLEX
⊕ _{1/2 HOT}	SPLIT WIRED DUPLEX
⊕ ₂₂₀	220 VOLT OUTLET
⊕ ₄	QUADRUPLEX
⊕ _{CEILING}	CEILING DUPLEX
⊕ _{FLOOR}	FLOOR DUPLEX
○	JUNCTION
⊕	DOOR BELL
⊕	GARAGE DOOR
⊕	PHONE OUTLET
⊕	TV OUTLET
⊕	SPEAKER
⊕	THERMOSTAT
⊕	SMOKE DETECTOR
⊕	CARBON MONOXIDE DETECTOR
⊕	CEILING LIGHT
⊕	RECESSED CEILING LIGHT
⊕	RECESSED EYEBALL LIGHT
⊕	WALL HUNG LIGHT
⊕	EYEBALL LIGHT
⊕	LANDSCAPING LIGHT
⊕	FLOODLIGHT
⊕	VENT
⊕	VENT AND LIGHT
⊕	HEAT AND LIGHT
⊕	HEAT AND VENT
⊕	HEAT, VENT AND LIGHT

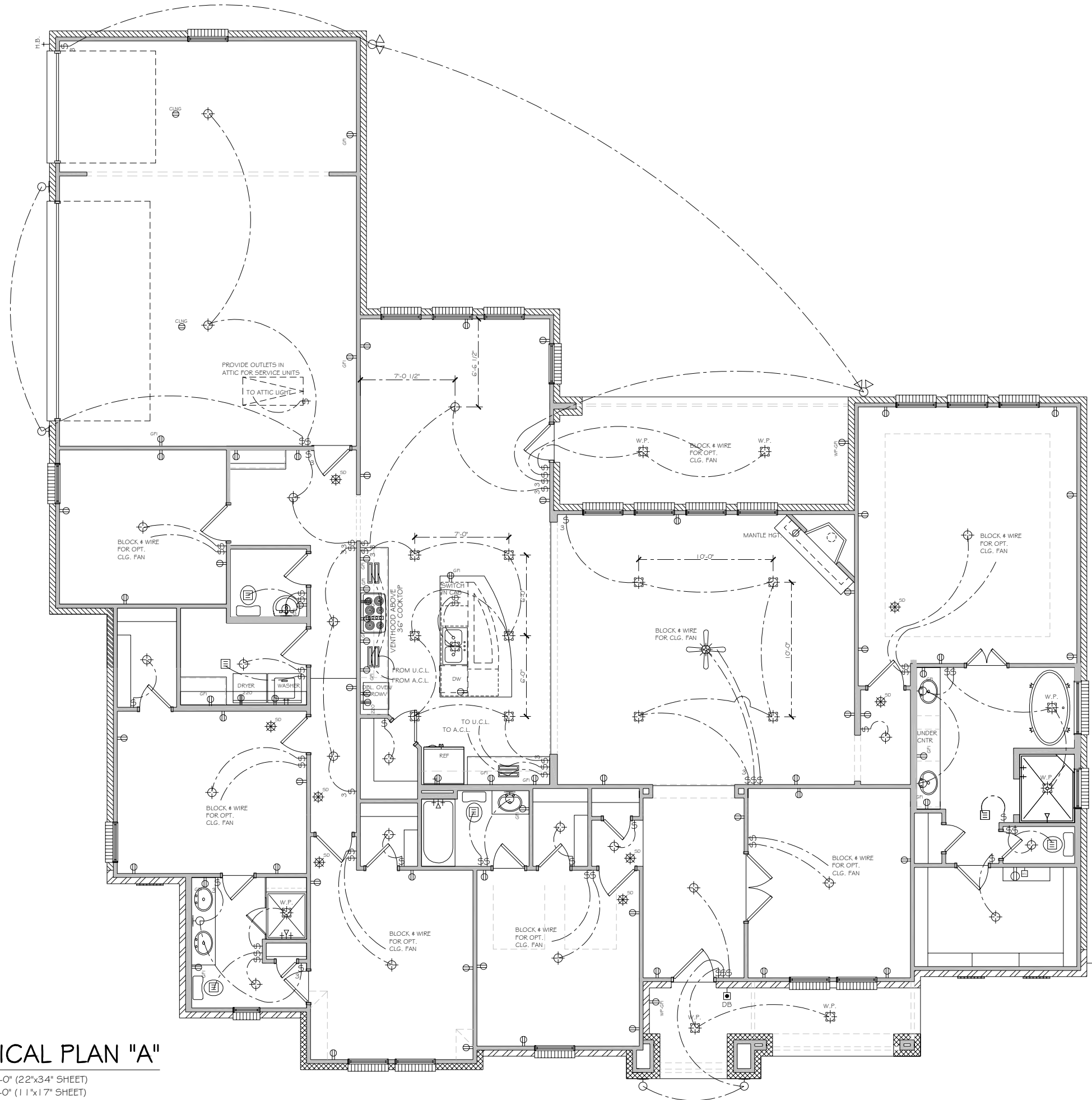

ELECTRICAL PLAN "A"
 SCALE: 1/4" = 1'-0" (22"x34" SHEET)
 1/8" = 1'-0" (11"x17" SHEET)

1501 LYNX LOOP, LOT 2 BLOCK E, LYNX HOLLOW, FORNEY TX

CONCEPT DATE:
12-6-16 NB
 PRINTED DATE:
3-23-17 NB, 9-11-17 NB,
8-2-18 NB, 2-28-20 NB,
3-9-20 NB, 5-26-20 SM

CRESCENT BUILDERS
 Phone: 972/999-4360
 www.builtbycrescent.com

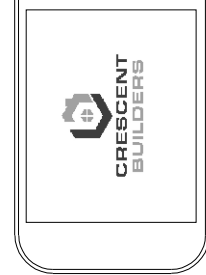

SCALE:
1/8" = 1'-0" (11x17) SHEET
 1/4" = 1'-0" (22x34) SHEET

PLAN NUMBER
3072
ELECTRICAL
PLAN "A"

PAGE 2 OF 7

1501 LYNX LOOP, LOT 2 BLOCK E, LYNX HOLLOW, FORNEY TX

CONCEPT DATE:
12-6-16 NB
PRINTED DATE:
3-23-17 NB, 9-11-17 NB,
8-2-18 NB, 2-28-20 NB,
3-9-20 NB, 5-26-20 SM

CRESCENT BUILDERS
Phone: 972/999-4360
www.builtbycrescent.com



SCALE:
1/8" = 1'-0" (11x17) SHEET
1/4" = 1'-0" (22x34) SHEET

PLAN NUMBER
3072
FRONT/ REAR
ELEVATIONS
"A"

PAGE 3 OF 7

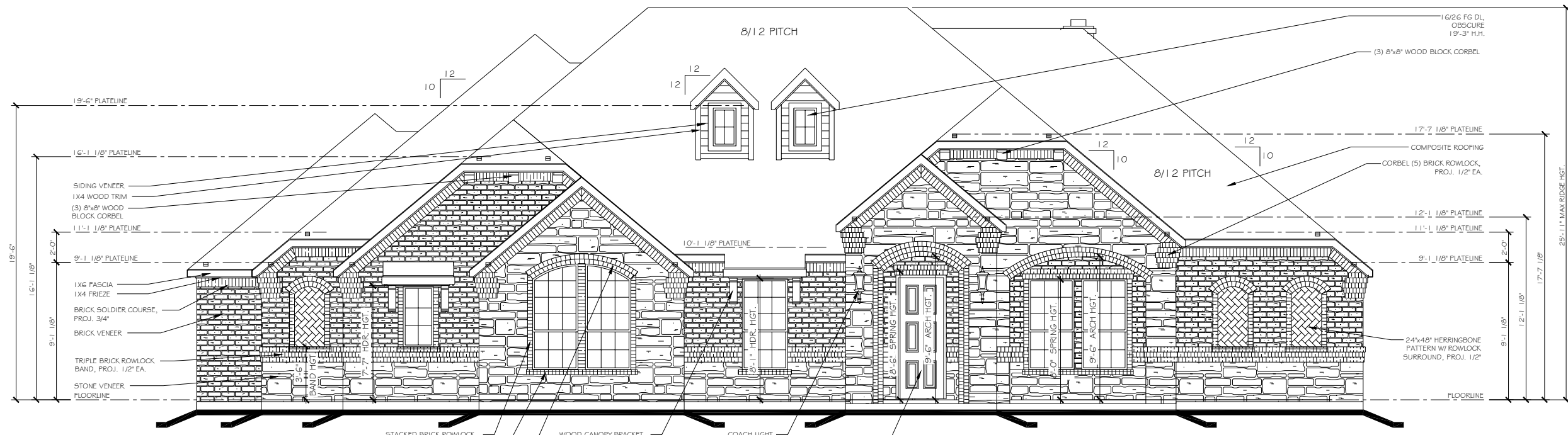

FRONT ELEVATION "A"

SCALE: 1/4" = 1'-0" (22x34" SHEET)
1/8" = 1'-0" (11x17" SHEET)

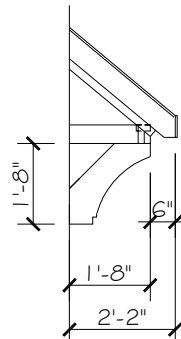

CANOPY BRACKET

SCALE: 1/2" = 1'-0" (22x34" SHEET)
1/4" = 1'-0" (11x17" SHEET)

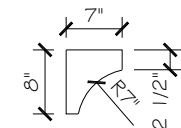

WOOD CORBEL

SCALE: 1" = 1'-0" (22x34" SHEET)
1/2" = 1'-0" (11x17" SHEET)

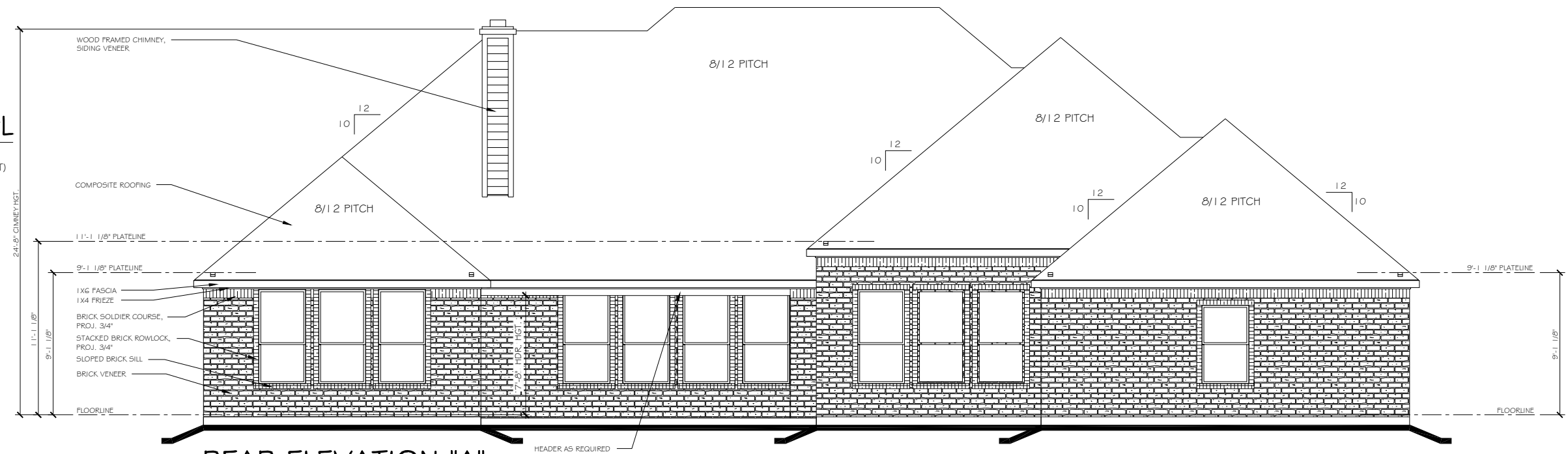

REAR ELEVATION "A"

SCALE: 1/4" = 1'-0" (22x34" SHEET)
1/8" = 1'-0" (11x17" SHEET)

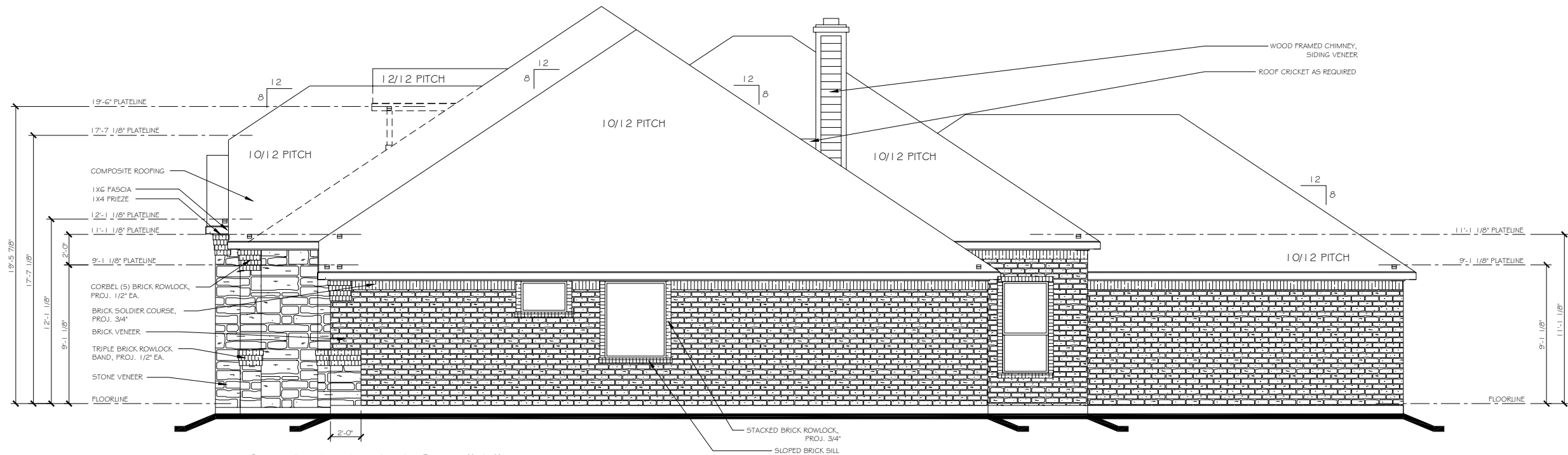

RIGHT ELEVATION "A"

SCALE: 1/4" = 1'-0" (22"x34" SHEET)
 1/8" = 1'-0" (11"x17" SHEET)

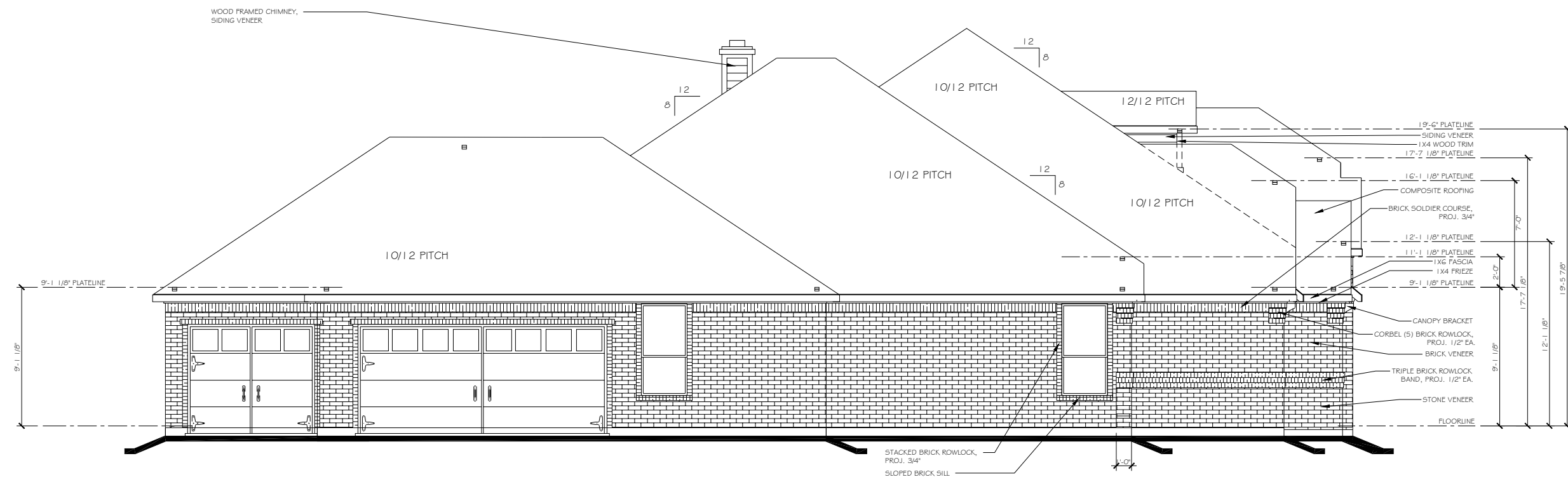

LEFT ELEVATION "A"

SCALE: 1/4" = 1'-0" (22"x34" SHEET)
 1/8" = 1'-0" (11"x17" SHEET)

1501 LYNX LOOP, LOT 2 BLOCK E, LYNX HOLLOW, FORNEY TX

CONCEPT DATE:
 12-6-16 NB
 PRINTED DATE:
 3-23-17 NB, 9-11-17 NB,
 8-2-18 NB, 2-28-20 NB,
 3-9-20 NB, 5-26-20 SM

CRESCENT BUILDERS
 Phone: 972/999-4360
 www.builtbycrescent.com



SCALE:
 1/8" = 1'-0" (11x17) SHEET
 1/4" = 1'-0" (22x34) SHEET

PLAN NUMBER
 3072
 SIDE
 ELEVATIONS
 "A"

PAGE 4 OF 7

ATTIC VENT CALCULATION	
NOTE: ATTIC AREAS WHICH USE THE 1:300 RATIO HAVE BEEN DESIGNED SO THAT 50% OF THE REQUIRED VENTILATION AREA IS PROVIDED IN THE UPPER PORTION OF THE ATTIC SPACE AND 50% IN THE LOWER PORTION.	
GENERAL CONTRACTOR SHALL VERIFY THE NET FREE VENTILATION OF THE VENT PRODUCT SELECTED AGAINST THOSE NOTED ABOVE. THE REQUIRED VENTILATION SHALL BE MAINTAINED. PROVIDE INSULATION STOP SUCH THAT INSULATION DOES NOT OBSTRUCT FREE AIR MOVEMENT AS REQUIRED BY THE BUILDING OFFICIAL.	
ALL OVERLAP FRAMED ROOF AREAS SHALL HAVE OPENINGS BETWEEN THE ADJACENT ATTICS IN THE ROOF SHEATHING (AS ALLOWED BY THE STRUCTURAL ENGINEER) TO ALLOW PASSAGE AND ATTIC VENTILATION BETWEEN THE TWO OR ISOLATED ATTIC SPACES SHALL BE VENTED INDEPENDENTLY TO IRC/IBC REQUIREMENTS.	
ALL CANTILEVERED FLOORS, CANTILEVERED ARCHITECTURAL POP-OUTS, AND ANY DOUBLE FRAMING PROJECTIONS THAT ARE SEPARATED FROM THE VENTING CALCULATIONS SHOWN ABOVE, PROVIDE A CONTINUOUS 2" CORROSION RESISTANT SOFFIT VENT AT UNDERSIDE OF FRAMED ELEMENT.	
FORMULA: 1 SQUARE INCH VENT FOR EVERY 300 SQUARE INCHES OF CEILING *144 SQ. IN. = 1 SQ. FT. BLDG. CEILING (SF) X 144 (SQ. IN.) BLDG. (SQ. IN.) / 300 = SQ. IN. OF VENT REQUIRED SQ. IN. OF VENT REQUIRED / 2 = 50% AT HIGH & 50% AT LOW (PER 2006 IRC SECTION R806.2)	
ATTIC AREA A	
4099 X 144 =	590256
590256 / 300 =	1967.52 OF VENT REQ'D
1967.52 / 2 =	983.76
983.76 OF VENT AT HIGH &	
983.76 OF VENT AT LOW	

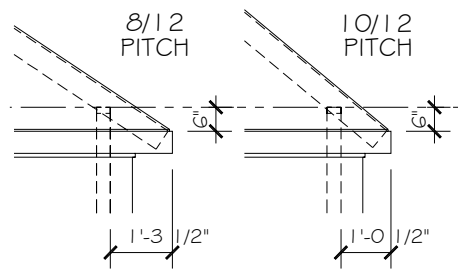

OVERHANG DEPTH

SCALE: 1/4" = 1'-0" (22"x34" SHEET)
 1/8" = 1'-0" (11"x17" SHEET)

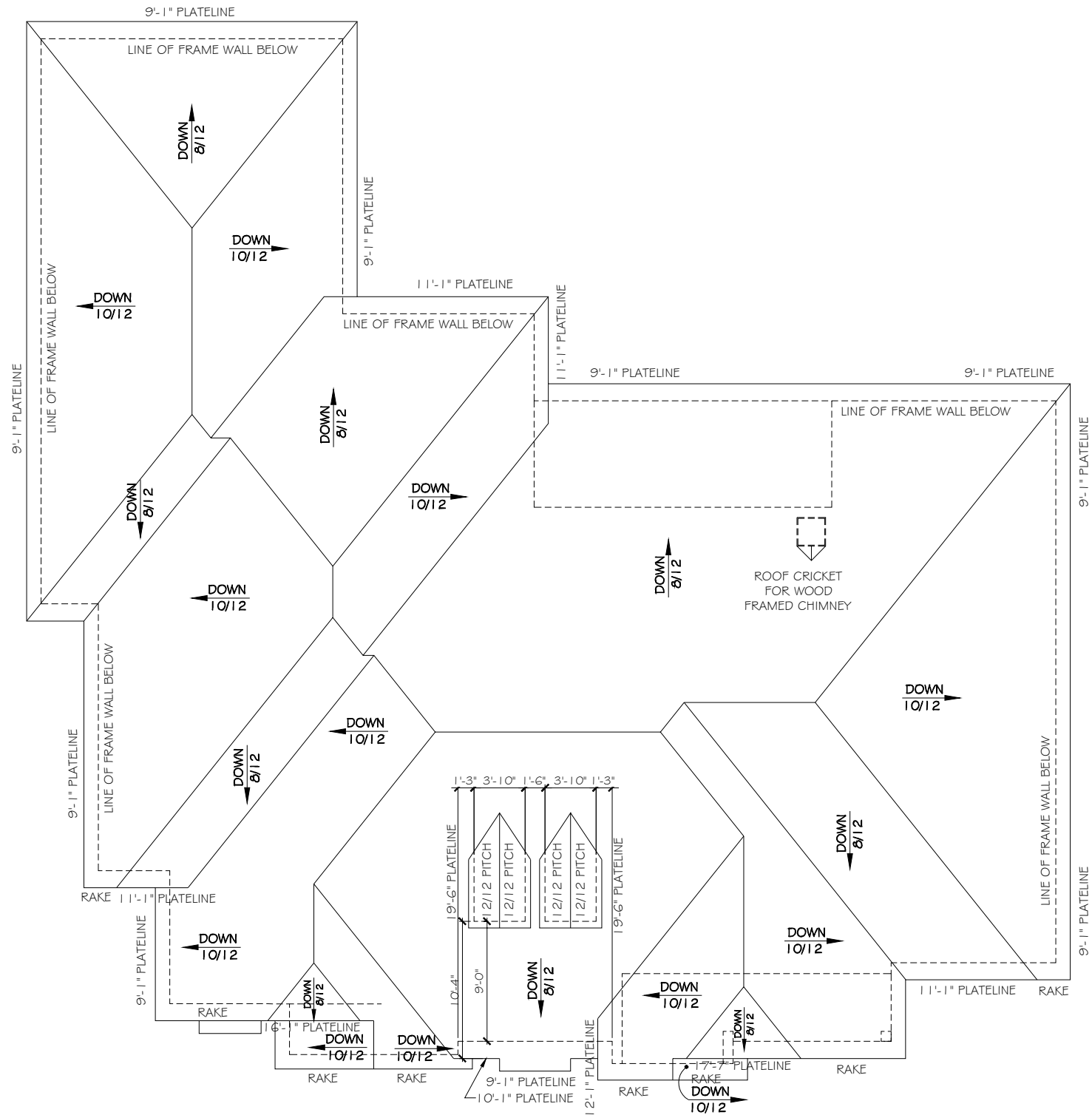

ROOF PLAN "A"

SCALE: 3/16" = 1'-0" (22"x34" SHEET)
 3/32" = 1'-0" (11"x17" SHEET)

1501 LYNX LOOP, LOT 2 BLOCK E, LYNX HOLLOW, FORNEY TX

CONCEPT DATE: 12-6-16 NB
 PRINTED DATE: 3-23-17 NB, 9-11-17 NB, 8-2-18 NB, 2-28-20 NB, 3-9-20 NB, 5-26-20 SM

CRESCENT BUILDERS
 Phone: 972/999-4360
 www.builtbycrescent.com



SCALE: 1/8" = 1'-0" (11"x17" SHEET)
 1/4" = 1'-0" (22"x34" SHEET)

PLAN NUMBER 3072
 ROOF PLAN "A"

TOP OF SLAB "A"
 SCALE: 1/4" = 1'-0" (22x34" SHEET)
 1/8" = 1'-0" (11x17" SHEET)

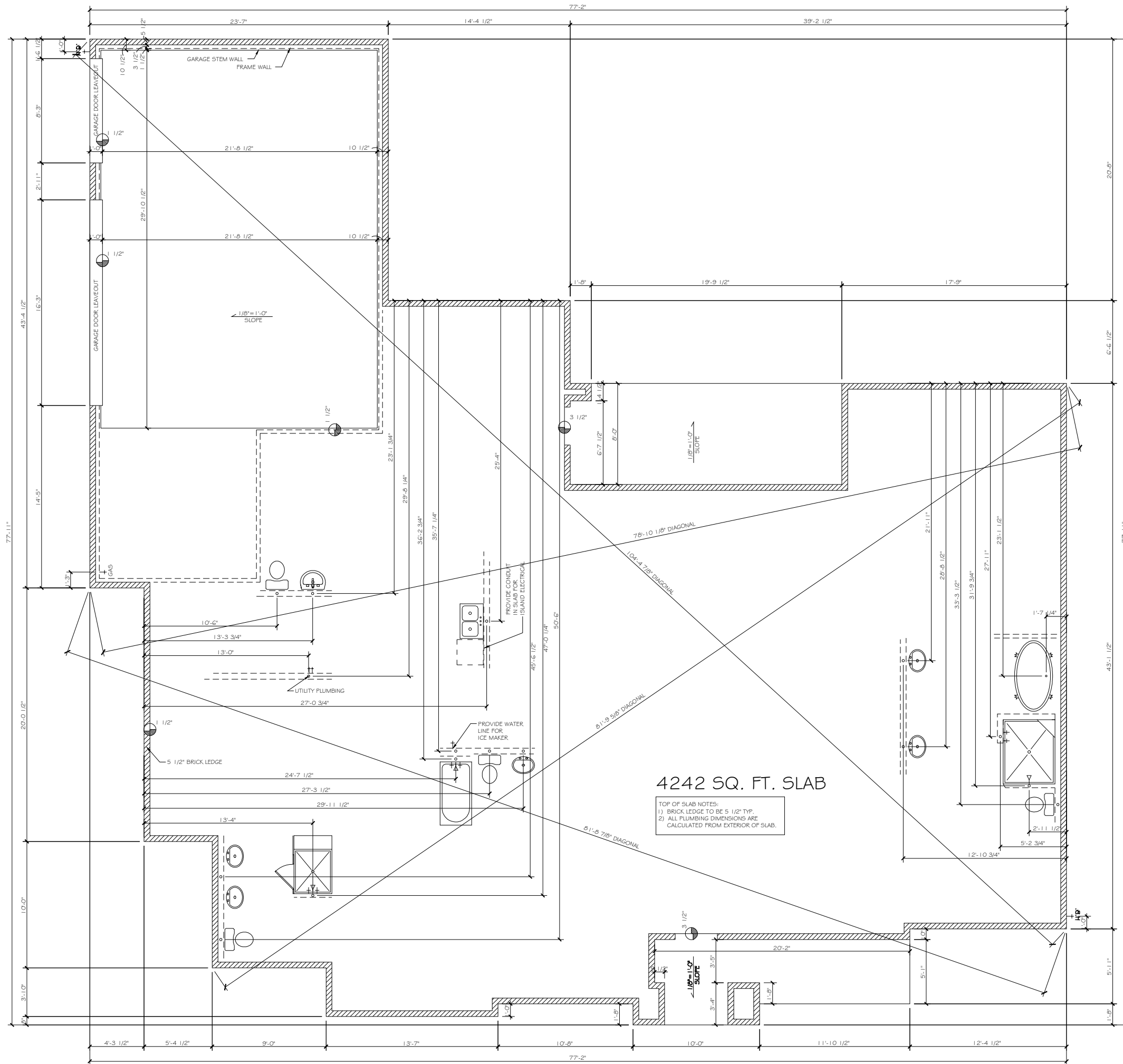

4242 SQ. FT. SLAB
 TOP OF SLAB NOTES:
 1) BRICK LEDGE TO BE 5 1/2" TYP.
 2) ALL PLUMBING DIMENSIONS ARE CALCULATED FROM EXTERIOR OF SLAB.

1501 LYNX LOOP, LOT 2 BLOCK E, LYNX HOLLOW, FORNEY TX

CONCEPT DATE:
 12-6-16 NB
 PRINTED DATE:
 3-23-17 NB, 9-11-17 NB,
 8-2-18 NB, 2-28-20 NB,
 3-9-20 NB, 5-26-20 SM

CRESCENT BUILDERS
 Phone: 972/999-4360
 www.builtbycrescent.com



SCALE:
 1/8" = 1'-0" (11x17) SHEET
 1/4" = 1'-0" (22x34) SHEET

PLAN NUMBER
 3072
 TOP OF SLAB
 "A"

PAGE 6 OF 7

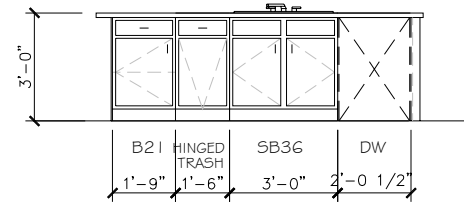

A KITCHEN ISLAND

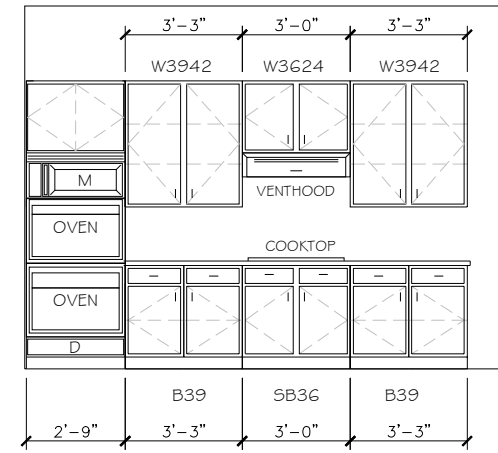

B KITCHEN

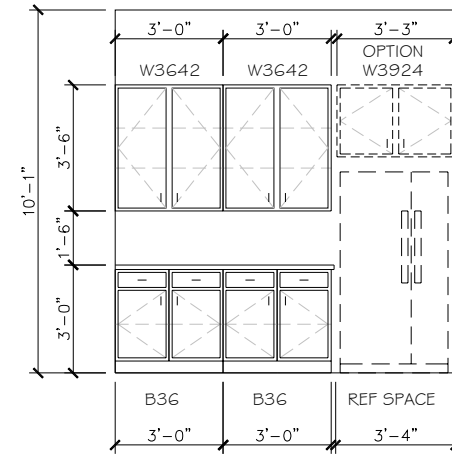

C KITCHEN

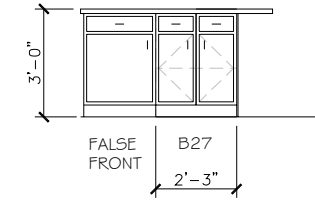

D KITCHEN ISLAND

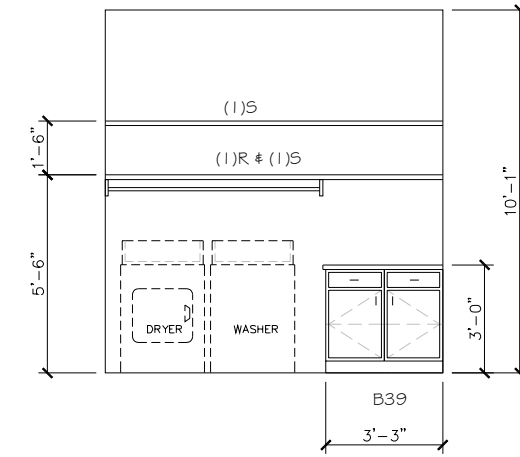

E UTILITY

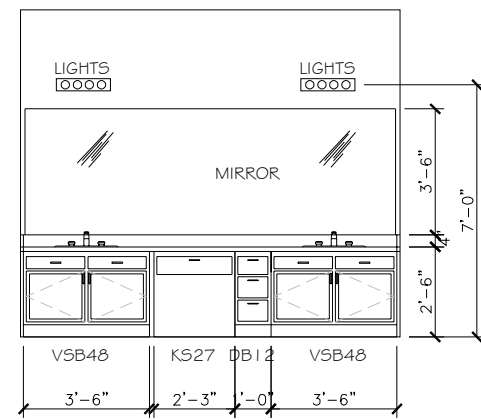

F MASTER BATH

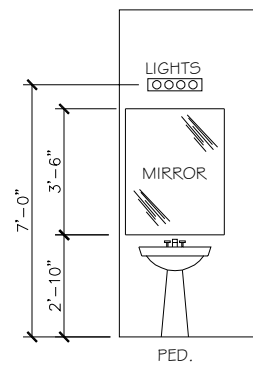

G POWDER #1

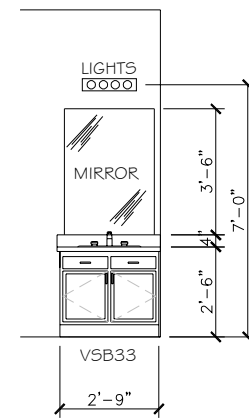

H BATH #2

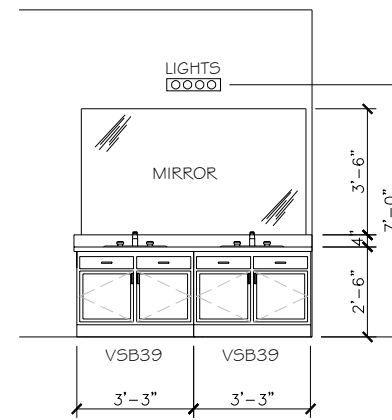

J BATH #3

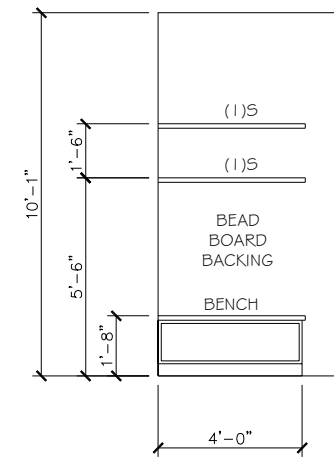

K MUD ROOM

CABINET ELEVATIONS

SCALE: 3/16" = 1'-0" (22"x34" SHEET)
3/32" = 1'-0" (11"x17" SHEET)

1501 LYNX LOOP, LOT 2 BLOCK E, LYNX HOLLOW, FORNEY TX

CONCEPT DATE: 12-6-16 NB
PRINTED DATE: 3-23-17 NB, 9-11-17 NB, 8-2-18 NB, 2-28-20 NB, 3-9-20 NB, 5-26-20 SM

THE SONOMA

CRESCENT BUILDERS
Phone: 972/999-4360
www.builtbycrescent.com



SCALE: 1/8" = 1'-0" (11x17) SHEET
1/4" = 1'-0" (22x34) SHEET

PLAN NUMBER 3072

CABINET ELEVATIONS

PAGE 7 OF 7